

Project

Item #

Quantity



SP8 Mixer

Model

SP8 - 8 Quart Planetary Mixer



GLOBE FOOD EQUIPMENT COMPANY

8 Quart Planetary Mixer

Standard Features

- **Motor and Transmission**
 - Gear driven, high torque transmission
 - Three fixed speeds
 - 1/4 HP custom built motor
 - Heat-treated hardened steel alloy gears and shafts
 - Permanently lubricated transmission
 - Thermal overload protection
- **Other**
 - Rigid cast aluminum base and column
 - Polycarbonate bowl guard
 - Front mounted controls
 - 15 minute digital timer
 - Separate start and emergency stop buttons
 - Safety interlock microswitches
 - Bowl guard
 - Bowl lift
 - 6 foot cord and plug

- **Standard Accessories**
 - 8 quart stainless steel bowl
 - Flat beater
 - Stainless steel wire whip
 - Spiral dough hook
- **Optional Accessories**
 - Stainless steel mixer table
- **Standard Warranty**
 - 2 year parts and one year labor

Approved By: _____

Date: _____



GLOBE FOOD EQUIPMENT COMPANY
www.globeslicers.com

2268 N. Moraine Dr.
Dayton, OH 45439
Phone: 937-299-5493
Phone: 800-347-5423
Fax: 937-299-4147

SP8



8 Quart Planetary Mixer

SP8

Specifications

Motor: 1/4 HP, grease packed ball bearing, air cooled, 110/60/1, 5 amps. Thermal overload protection (manual reset).

Finish: NSF approved enamel white paint.

Capacity: 8 quart (7.6 liter) bowl.

Transmission: Heat treated, hardened alloy, precision milled gears operate with planetary action. Gears are packed in a long lasting grease. All shafts are mounted in ball bearings. Transmission gears are driven by direct linkage to the motor drive shaft. This design yields high torque mixing power.

Agitator Speeds (RPMs):

Low	132
Intermediate	234
High	421

Standard Equipment: Standard equipment includes an 8 quart #304 series stainless steel bowl, spiral dough hook, stainless steel wire whip, flat beater, polycarbonate bowl guard, and a 15 minute digital timer. A sturdy hand lever on the body column raises and lowers the bowl as well as locking in place at the top and bottom positions.

Safety Features: Separate start and emergency stop button so operators can shut down the mixer in an emergency situation, and microswitches that automatically shut the mixer down when the guard is opened or the bowl is lowered.

Cord and Plug: 6 ft. flexible three wire cord and ground plug.

Dimensions:

Foot Print = 11.8" x 15.8"
(30.0 cm x 40.1 cm)
Overall Length = 15.8" (40.1 cm)
Overall Width = 11.8" (30.0 cm)
Overall Height = 22.9" (58.2 cm)

Shipping Information:

Freight Class: 77.5
Net Weight: 55 lbs. (25 kgs.)
Shipping Weight: 62 lbs. (28.1 kgs.)
Shipping Dimensions:
20"W x 16"D x 26"H
(50.8cm W x 40.6cm D x 66.0cm H)
Cartons are reinforced for shipping. The weight and dimensions of this reinforced carton are included above and may vary from shipment to shipment.

Optional Accessories:

XTABLE Stainless Steel Mixer Table with Undershelf
30"W x 24"D x 24"H
(76.2cm W x 61.0cm D x 61.0cm H)

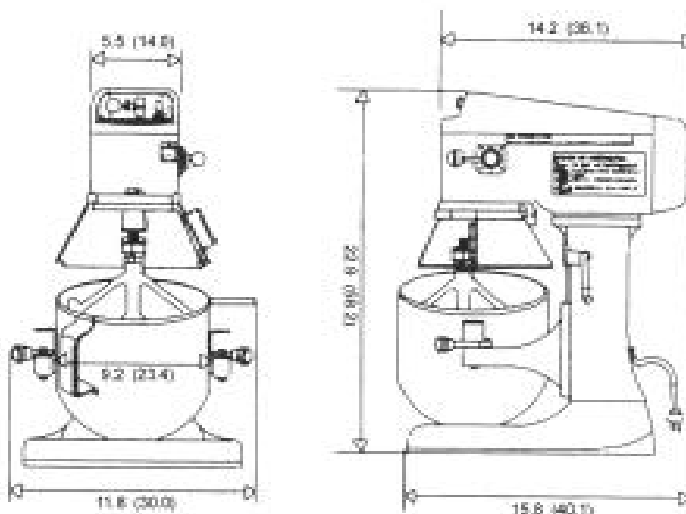

UNIT: INCHES (CM)



GLOBE FOOD EQUIPMENT COMPANY

www.globeslicers.com

2268 N. Moraine Dr.
Dayton, OH 45439
Phone: 937-299-5493
Phone: 800-347-5423
Fax: 937-299-4147

Printed in U.S.A. 2-2004