



TRUE FOOD SERVICE EQUIPMENT, INC.

St. Charles Industrial Center • P.O. Box 970 • O'Fallon, Missouri 63366
(636)240-2400 • FAX (636)272-2408 • (800)325-6152 • www.truemfg.com

Project Name: _____

AIA #

Location: _____

SIS #

Item #: _____ Qty: _____

Model #: _____

Specification Series

**TR (Deep Reach-In)
Half Door Freezer Series**



TR1F-2HS

True introduces its latest offering designed specifically to meet the needs of consultants.

**Deep Reach-In
Half Door Freezer**

TR1F-2HS

SPECIFICATIONS / FEATURES

DOORS:

- 300 series stainless steel exterior with 300 series stainless steel interior to match cabinet liner. Doors extend full width of cabinet shell. Door gaskets of one piece construction.
- Lifetime guaranteed adjustable torsion type closure system with extruded aluminum and stainless steel supports. The face of each door fitted with a 12" long recessed handle with interlock (lifetime guarantee on all handles and door hardware). Handles are foamed-in-place to insure permanent attachment.

INSULATION:

- Entire cabinet structure and doors insulated using foamed-in-place CFC free polyurethane foam.

SHELVING:

- Heavy gauge full or half height pilasters and tray slides/shelving factory installed at no charge.
- Interior kit must be indicated at time of order.
Note: Tray slide sets and shelves can also be ordered individually.
- (1) interior kit option included per section at no charge.
(4) different interior kits available. See "optional accessories" section.

- Standard backguard improves airflow.

LIGHTING:

- Incandescent interior lighting. Light(s) activated by rocker switch mounted above door(s).

REFRIGERATION SYSTEM:

- Oversized refrigeration system factory balanced using CFC free R404A refrigerant.
- Top mounted condensing unit.
- Factory pre-engineered capillary tube system with oversized condenser and evaporator to reduce product pull down time and to consistently maintain food safe -10°F interior cabinet temperature.
- Defrost system time initiated, temperature terminated.
- Automatic evaporator fan motor delay during defrost cycle.
- Large evaporator and coil heater permit short defrost cycle.
- Evaporator - epoxy coated at the time of manufacture to eliminate the potential of corrosion.

ELECTRICAL CHARACTERISTICS:

- Unit completely pre-wired at factory, and ready for final connection to a dedicated outlet. A cord and plug set to be included.
- A sole use circuit is required.



115/60/1
NEMA-5-15R

SPECIFICATIONS / FEATURES

CABINET CONSTRUCTION:

- Exterior - 300 series stainless steel front, shroud and doors. 300 series stainless steel exterior ends, top, back, and bottom.
- Interior - 300 series stainless steel interior cabinet side walls, back, door liner and floor. Construction of liner in accordance with NSF standards.
- Barrel lock standard for each door. Locks keyed alike.
- Digital exterior temperature monitor with manual defogger control, large LED display for quick and easy temperature identification.
- Cabinet mounted on a welded, galvanized frame rail, enamel dipped and baked for permanent bond on all surfaces, provides additional corrosion protection. Frame rail fitted with 4" diameter polyolefin castors, (front castors include brakes).

Remote cabinets available 14% off list (condensing units supplied by others). Consult factory technical service dept. for BTU information.

Curb mountable units for TR/TA/TG series only. (5% list upcharge)

Specifications subject to change without notice.

Printed in U.S.A.



APPROVALS:

10/03

Exceptions:

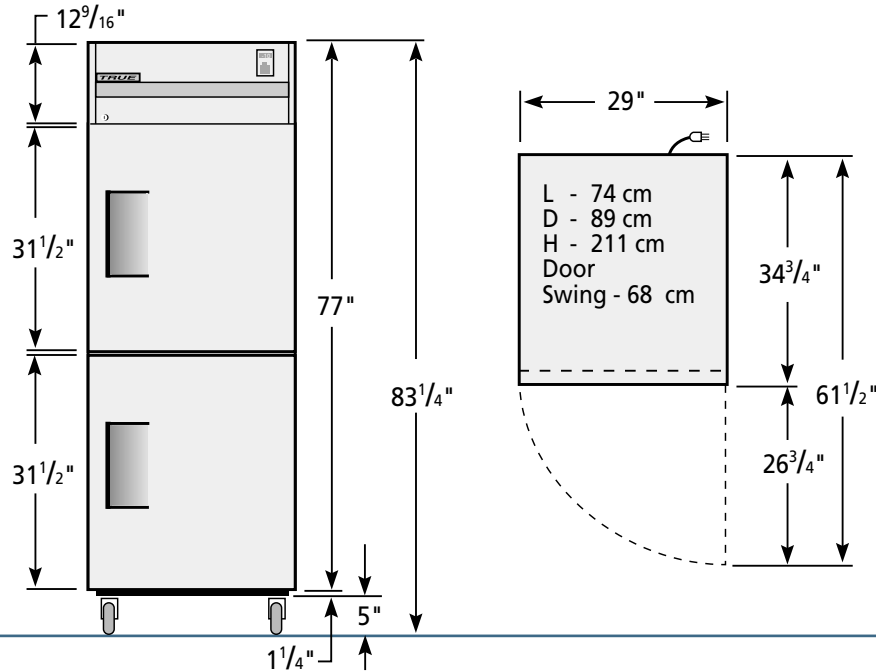

Rough-In Data												
Model	Doors	Capacity (Cu. Ft)	Dimensions (inches)			HP	Volts	PH	Amps	NEMA Config.	Cord Length (feet)	Crated Weight
			L	D	H*							
TR1F-2HS	2	31	29	34 3/4	78 1/4	1/2	115	1	10.8	5-15	9	410

* Height does not include 5" for castor height or 6" for optional legs.

Specifications subject to change without notice.

Standard Features

- Oversized and balanced, environmentally friendly (R404A) refrigeration system holds -10°F.
- Exterior - 300 series stainless steel front, doors, sides, top, bottom and back (the finest stainless available).
- Interior - 300 series stainless steel side walls, back, door liner & floor.
- 300 series stainless steel doors with recessed handles (lifetime guaranteed).
- Door locks standard.
- Exterior mounted digital electronic thermometer with manual defogger.
- Wide door openings.
- Half-doors allow product segmentation for easy access.
- (1) interior kit option included per section at no charge. (4) different interior kits available.
- Pilasters and tray slides/shelving factory installed at no charge. Kit selection must be indicated at time of order.
- Magnetic door gaskets.
- Epoxy coated evaporator.
- Incandescent interior lighting.
- 4" diameter swivel castors standard equipment - locking castors provided for front set.
- Large evaporator and coil heater permit short defrost cycle.
- Defrost system time initiated, temperature terminated.
- Automatic evaporator fan motor delay during defrost cycle.
- Minimum wattage heater in cabinet frame and door.
- Standard backguard - improves airflow.
- Hot gas condensate for energy efficiency.
- Top mounted unit positioned out of food zone to maximize storage capacity.
- Foamed-in-place polyurethane high density cell insulation (CFC free).
- Positive seal self-closing doors with factory tested (over 1,000,000 times) lifetime guaranteed door hinges and torsion type closure system.

- Self-contained system.
- 1 year parts & labor warranty (USA).
- 5 year compressor warranty (USA).

Optional Accessories

- 6" stainless steel legs.
- Seismic/Flanged legs.
- Kit #1 (9 sets of #1 type tray slides).
- Kit #2 (rod type 1 set covers 1/2 section).
- Kit #3 (6 sets of universal type tray slides).
- Kit #4 (3 chrome shelves and shelf supports)
- Stainless steel (electro polished) shelves.
- Chrome shelves.
- Metal handle (solid doors only).
- Cam lift hinge (solid door models only).
- Electronic temperature control.
- Universal pan slides.
- #1 pan slides.
- #2 or rod style pan slides.
- Curb mountable units.
- Export units available - consult factory.
- Correctional facility options - consult factory.
- Remote cabinets available (contact factory technical services for BTU information).

	Model	Front	Right	Plan	3D
	TR1F-2HS	TFQX60E	TFQX60S	TFQX60P	TFQX603