

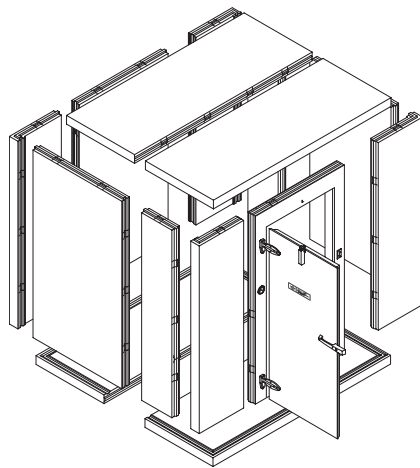

WALK-IN COOLER AND FREEZER MANUAL



Specifications

Installation Instructions

Trouble Shooting

Warranty

Drawings

Quote Form

U.S. Cooler
325 Payson Avenue, Quincy, Illinois 62301
800.521.2665 Fax 217.228.2424
www.uscooler.com



Extruded Polystyrene Walk-in Cooler/Freezer Specifications

Size:

Walk-in shall be _____ x _____ x _____.

Construction:

Walk-in shall be manufactured to National Sanitation Foundation requirements and shall bear the NSF Seal of Approval and U.L. Certification. Unit shall be constructed of modular panels allowing easy set-up and installation of walk-in. Panels shall be connected together by cam lock connectors activated by an L-shaped allen wrench supplied with walk-in. Cam locks must be able to be moved in case of future modifications. Unit must have capacity to be easily disassembled for relocation or future expansion.

Drawings:

Complete shop drawings must be supplied by Manufacturer and submitted to customer for approval prior to manufacture.

Materials:

Walls, ceilings, and floor shall consist of interior and exterior metal laminated to rigid, extruded foam insulation. All wall, ceiling, and floor panels, shall be manufactured using no wood products unless noted. A double-barreled vinyl gasket shall be provided on panel edges to provide a vapor proof seal. Vinyl gasket must be installed so back edge of gasket material wraps around metal skin.

Insulation:

All wall and ceiling insulation shall be 4" thick, high quality, rigid virgin Extruded Polystyrene (Foamular® 250, supplied by Owens Corning or PC-30 supplied by Dow Chemical) for insulation, 1.6 lb. Density. K factor of not more than .125 and an R factor of no less than 8 per inch, initial fresh R-32 minimum total walls R factor. Vapor transmission shall be less than 1 perm and foam core material must meet UL 25 flame spread rating with average smoke rating less than 165.

Electrical:

All electrical items shall be UL approved for use in walk-in environments.

Metal:

All galvanized, galvalume, and white wall, ceiling and exterior floor skins shall be 26 gauge. All stainless steel walls and ceilings shall be 24 gauge. All stainless steel floors shall be 22 gauge.

Entrance Door:

Door opening shall be _____" x _____". Door shall be a self-closing flush mount style with magnetic gasket and come complete with quality chrome latches and hinges. Latch shall have inside safety release handle. Door shall be fitted on top and both sides with magnetic gasket enclosed between 2 each 1/2" vinyl sweeps when door is closed. Frame shall be equipped with door heater wire channel with snap on and off 1 1/4" stainless steel cover. In freezer applications, door heater wire shall be temperature self-regulated and field replaceable. Door shall be equipped with automatic self-closer, vapor proof light, junction box, and light switch with pilot. Bottom edge of door shall be fitted with replaceable triple-edge wiper type sweep, which shall provide a seal resistant to oil, fats, water, and abrasion. Door bears U.L. Certification.

Packaging:

Units shall come palletized on skids with protective corners, banding and covered in plastic wrap.

Expanded Polystyrene Walk-in Cooler Specifications

Size:

Walk-in shall be _____ x _____ x _____.

Construction:

Walk-in shall be manufactured to National Sanitation Foundation requirements and shall bear the NSF Seal of Approval and U.L. Certification. Unit shall be constructed of modular panel allowing easy set-up and installation of walk-in. Panels shall be connected together by cam lock connectors activated by an L-shaped allen wrench supplied with walk-in. Cam locks must be able to be moved in case of future modifications. Unit must have capacity to be easily disassembled for relocation or future expansion.

Drawings:

Complete shop drawings must be supplied by Manufacturer and submitted to customer for approval prior to manufacture.

Materials:

Walls, ceilings, and floor shall consist of interior and exterior metal laminated to rigid foam insulation. All wall, ceiling, and floor panels, shall be manufactured using no wood products unless noted. A double-barreled vinyl gasket shall be provided on panel edges to provide a vapor proof seal. Vinyl gasket must be installed so back edge of gasket material wraps around metal skin.

Insulation:

All wall and ceiling insulation shall be 4" thick, high quality, rigid expanded Polystyrene for insulation, 1 1/4 lb. Density, type VIII. A K factor of not more than fresh .22 and an R factor of no less than 4.5 per inch, initial R-18 minimum total walls R factor. Vapor transmission shall be less than 1.7 perm and foam core material must meet UL 25 flame spread rating with average smoke rating less than 150.

Electrical:

All electrical items shall be UL approved for use in walk-in environments.

Metal:

All galvanized, galvalume, and white wall, ceiling, and exterior floor skins shall be 26 gauge. All stainless steel walls and ceilings shall be 24 gauge. All stainless steel floor shall be 22 gauge.

Entrance Door:

Door opening shall be _____" x _____". Door shall be a self-closing flush mount style with magnetic gasket and come complete with quality chrome latches and hinges. Latch shall have inside safety release handle. Door shall be fitted on top and both sides with magnetic gasket enclosed between 2 each 1/2" vynal sweeps when door is closed. Frame shall include snap on and off 1 1/4" stainless steel cover to allow magnetic gasket to seal. Door shall be equipped with automatic self-closer, vapor proof light, junction box, and light switch with pilot. Bottom edge of door shall be fitted with replaceable triple-edge wiper type sweep, which shall provide a seal resistant to oil, fats, water, and abrasion. Door bears U.L. Certification.

Packaging:

Unit shall come palletized on skids with protective corners, banding and covered in plastic wrap.

Installation Instructions



General:

- Check bill of lading for correct number of skids.
- Put on gloves before handling any panels.
- Check and report to trucking company and U.S. Cooler any damaged or missing items immediately.
- Remove packing list at end of skid and installation pack on door.
- Locate freezer/cooler drawing in installation pack (**see figure 1**) along with cam wrench (large L shaped allen wrench).



Tools Required:

- Cam-lock wrench (Provided)
- Gloves for handling panels
- Caulk gun and NSF silicone caulk
- Power drill with phillips driver and 1/8" drill bit
- Rivet Gun
- 1/2" metal drill bit



Floor Installation (Floored Units):

Locate skid(s) that have panel numbers starting with the letter F. These are floor panels. Using chalk line, measure out and mark floor for location of box. Lay the F1 floor-panel in the location designated on the floor plan drawing (**see figure 2**). Take the F2 floor panel and fit male side of F1 panel into female side of F2 panel. Align both ends until they are even (**see figure 3**). Insert cam wrench into center hole on F1 panel. If hook is showing, back cam counter clockwise until you reach a stop, but do not force cam. Turn cam wrench clockwise until a solid stop is reached (**see figure 4**). Again, do not force past stop. Check to see if F1 and F2 floor panels are firmly attached together. If not, repeat this step. Otherwise, lock remaining cams and go to next panels until all floor panels are assembled.



Screeding Installation (Floorless Units):

Using chalk line, mark location of box walls according to enclosed plans (**see figure 5**). Add 1/2" to each side for screeding oversize. Lay two beads of silicon caulk within the 4" wall location (**see figure 6**). Gray screeding can optionally be screwed down with Tapcon screws placed directly in the center of screeding (**see figure 7**). Seal top of screeding where it contacts metal skin with NSF approved silicone caulk.



Wall Panels Installation:

Start with corner wall consisting of W1 and the adjacent wall panel that forms the corner (**see figure 8**). On floor-less walk-ins, work panels into pre-installed screeding. On floored units, place male bottom of wall panel in female groove of floor panel. Make sure the floor arrow on the wall panel is pointing down. Once panel is inserted correctly, install W2 wall panel with W1 panel, male edge will be inserted into female edge of W2 panel. Special care should be given to ensure that top edges and sides of wall panels are flush (**see figure 9**). Take cam wrench and insert it into center hole of W1 panel. Be sure cam lock is set by first turning wrench in a counter clockwise direction until stop is felt. Do not force cam. After checking set of cam, turn wrench in a clockwise direction until stop is felt (**see figure 10**). Again, do not force cam. Check to see if panels are firmly locked together. If not, repeat this step. If they are, finish panel installation by locking all wall cams. Do not lock the panels to the floor until all wall and ceiling panels have been locked together. Continue installing wall panels by alternating from the lowest wall number to the highest wall number. On combination



units, install center wall before continuing into cooler section. If the floor is uneven, adjustments must be made to ensure wall panels are flush at the top. When installing door panel, remove door by lifting door in an upward direction on panel and set aside until the frame is installed.

Door Installation:

Doors on rapid ship units can be installed in any of the standard full size wall panel locations, while special order units have fixed door locations. A door threshold hold down bar must be installed in the floor panel where the door is going to be installed. Place the hooks of the door threshold hold down bar, with the hooks going in the same direction of the cams, in to the slots on the cams. The hook on the bar should contact the pins in the cams. Gently tap the hold down bar in the direction of the cams and hooks until it quits moving, locking it in place with the cam hooks (approx. 1 1/2"). Continue installation of wall panels.

Ceiling Panels Installation:

Once wall panels are installed, proceed with C1 ceiling panel by placing it in location according to drawing (see figure 11). Align it so it is even on all edges. Many times uneven floors may cause ceiling to either be slightly bigger or smaller than wall panels. If this is the case, split the difference. All panels are made to allow adjustments due to varying installation conditions. Lock all cams according to previous instruction. After locking C1 panel, lift C2 panel into location so male side of C1 fits into female side of C2. Line up both ends and lock all cams (see figure 12). Continue installing ceiling panels from smallest number to largest number.

Door Adjustments:

After all panels have been installed, close walk-in door. If the door does not shut correctly, verify that the reveal between the door and frame is even around the perimeter (see figure 13). A reveal that increases or decreases across the top of the door indicates one leg of the door frame is lower than the other and will need to be shimmed to correct the condition. The door and frame should be flush around the perimeter. If one corner of the door protrudes from the frame, it indicates that the bottom of one door leg is not aligned with the other leg & the frame has a slight twist. Unlock the cams around the perimeter of the frame and move the door leg in or out to correct the condition, then re-lock the cams. Once box is completely installed and door alignment is verified, screw the threshold down to the threshold hold down bar on floored boxes and to the floor on floorless boxes with the stainless steel screws provided. On floorless units, attach L-shaped hold down bracket to door legs and floor (see figure 14).

Caulking Instructions:

It is advisable, but not absolutely necessary, to caulk all joints inside walk-in. This will provide for an even better sealed unit. Use NSF approved silicone type caulking.

Rain Roof Installation:

Install evaporator coil prior to rain roof installation and silicone caulking around the carriage bolt heads to avoid perforating the rain roof. For rain roof installation, place vinyl-roofing material, with flaps underneath, on top of walk-in across narrow end. Allow 6"



(Continued on next page)

Installation Instructions (continued)

Rain Roof Installation (continued):

of vinyl to lap over each of the three sides. Carefully unroll vinyl material across walk-in until vinyl flap falls into position. Take a stainless steel screw and square plate and screw through plate and flap in the middle of flap. Then screw a plate at each end of flap. Install screw and plate every foot across flap. Continue to roll out vinyl until the end or the next flap, then repeat screwdown process. Once the end is reached, it should lap over end by at least six inches. For units installed up against buildings, lap vinyl 1 foot up the wall, fold vinyl back and run two beads of Mastik caulk along wall edge 3" above walk-in. Then fold vinyl twice so there is 4" left to fasten plastic strip to building with. Fasten plastic strip over vinyl with stainless steel screws or galvanized nails. Place round piece of vinyl over each corner to protect against vinyl puncture. Place a bead of caulking around top sides of walk-in 5" below top of unit. Place plastic strip on top of vinyl so bottom of plastic strip falls 6" from the top. Screw into side of walk-in with stainless steel screws. Fold corners and continue around box on all four sides. Note: If vinyl hangs over more, cut off extra or fold extra under plastic strips.

Refrigeration Installation:

For side mount units, set refrigeration system over notched wall panel with compressor mounted on outside of walk-in. Drill through wall with 1/2" drill bit and bolt unit on with provided bolts. If unit has top mount self-contained refrigeration system to be installed, place unit in prefabricated hole in top of walk-in with air flow marker pointing away from wall. Caulk around perimeter of refrigeration unit. All refrigeration components must be installed by a certified refrigeration contractor, who must be present at startup. This may affect your warranty.

Troubleshooting

Ceiling overhangs walls:

If walls are racked at the top, loosen wall cams and adjust walls so the tops of the walls line up. If walls are level at the top, loosen corner wall panel and bump out wall panel to line up with outer edge of ceiling. Lock ceiling to wall and relock corner seam.

Door doesn't shut:

Check to make sure door closer is working properly and it is catching the hook. Checks to make sure walls aren't racked. See installation instructions for further door alignment information.

Door sags:

Check to make sure the floor is level. If not, shim as needed under correct door leg.

Ceiling panels won't pull down to lock into walls:

If walls have been locked to walk-in floor, unlock walls from the floor, lock ceiling panels down to walls and relock walls to floor.

Cam wrench is binding in cam hole:

Only insert the wrench far enough to catch the mechanism. Make sure you are inserting the tapered end of the wrench in the hole.

Cam lock not engaging (locking):

Make sure adjoining wall panels are flush on sides and top, so cams are lined up properly. Before locking, be sure to reset cam by turning it counter-clockwise until it resets. Do not over-reset cam. Then relock cam.

Door thermometer reads incorrect temperature:

Door thermometer doesn't register proper temperature. Make sure that the temperature probe is toward the center of the walk-in. Door thermometer may need to be calibrated. Place index finger on wide end of pointer. Insert screwdriver in pointer's slot and turn either clockwise (lowering temperature) or counter-clockwise for raising temperature

Customer Service Contact Information:

U.S. Cooler Company
325 Payson Avenue
Quincy, IL 62301

Toll Free: 800.521.2665
Phone: 217.228.2421
Fax: 217.228.2424

Email: customerservice@uscooler.com
Company Website: www.uscooler.com
Parts Website: www.walkincoolerparts.com

U.S. Cooler Ten Year Limited Warranty

U. S. Cooler Company, Inc. warrants to the original purchaser that the walk-in panels manufactured by the company are free from any defect in material or workmanship under conditions of normal use and service. The obligation of the manufacturer under this warranty shall be limited to repairing or replacing at their option FOB factory, panels of said walk-in which proves defective within ten years from the date of purchase. All hardware carries a standard one-year warranty.

Refrigeration equipment carries a standard one-year factory warranty for compressor and accessories. The obligation of the manufacturer under this warranty shall be limited to repairing or replacing at their option FOB factory, any part of said refrigeration system which proves defective within one year from the date of purchase. An extended four-year compressor warranty and a 1st day through 5th year labor warranty are also available as an option.

This warranty is in lieu of all other warranties expressed or implied and does not apply to equipment, which has been subject to any accident, alteration, abuse, misuse or improper installation. U.S. Cooler Company, Inc. expressly disclaims all other warranties expressed or implied. The standard warranty does not include any labor charges for replacement or repair of defective parts. In no event shall U.S. Cooler Company, Inc. be liable for any special, direct or indirect, incidental or consequential damages or for any lost product, lost profits or revenues or other losses or damages caused by lost product or lost profits or revenues, whether for breach of warranty or otherwise.

For warranty work on your U. S. Cooler walk-in cooler or freezer, call our Customer Service Department immediately. You will then be advised of the proper procedure to follow. NO warranty work is to be performed without an authorization number, which will be provided by the Customer Service Manager. U.S. Cooler assumes no responsibility for work performed without an authorization number.

Walk-in Cooler/Freezer Exploded View

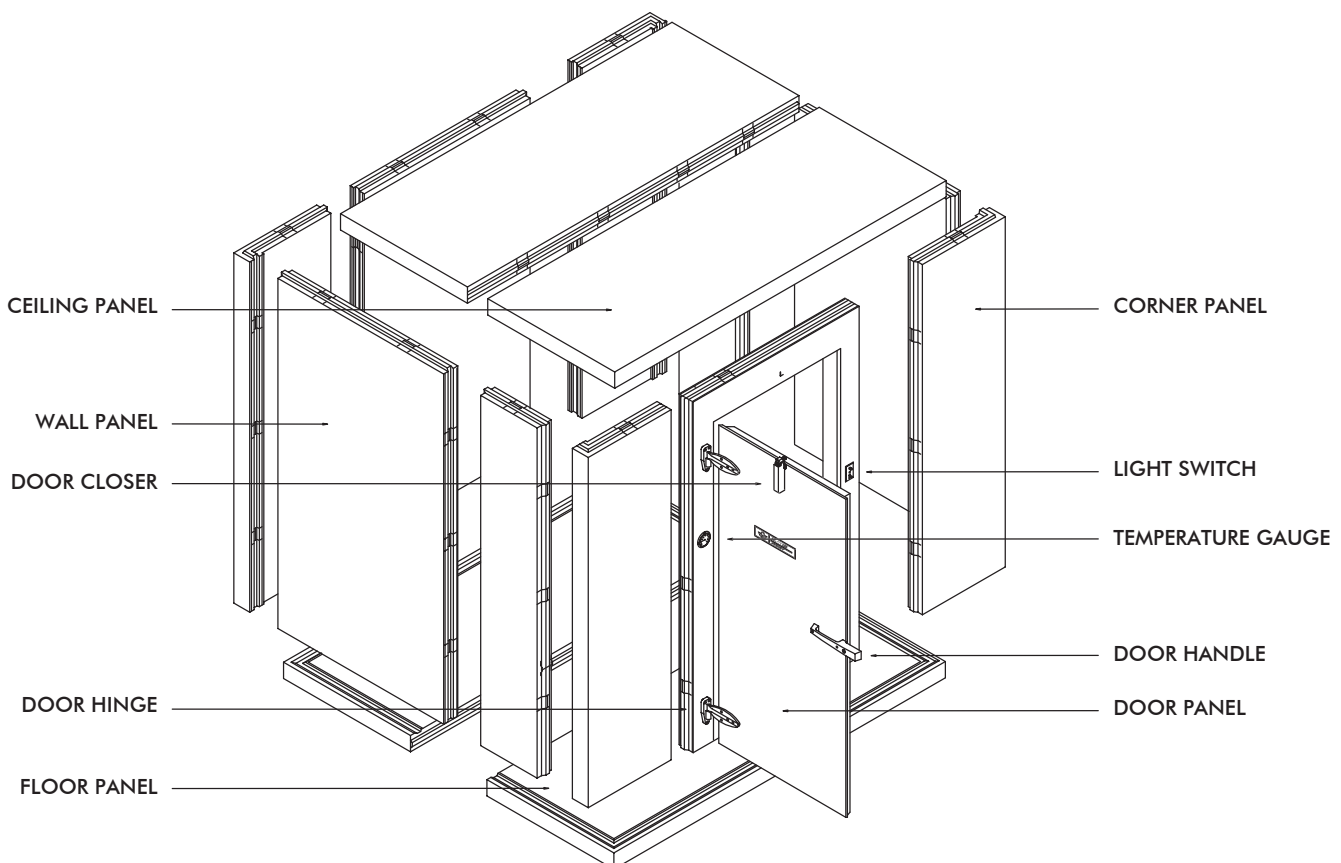

Door Drawings

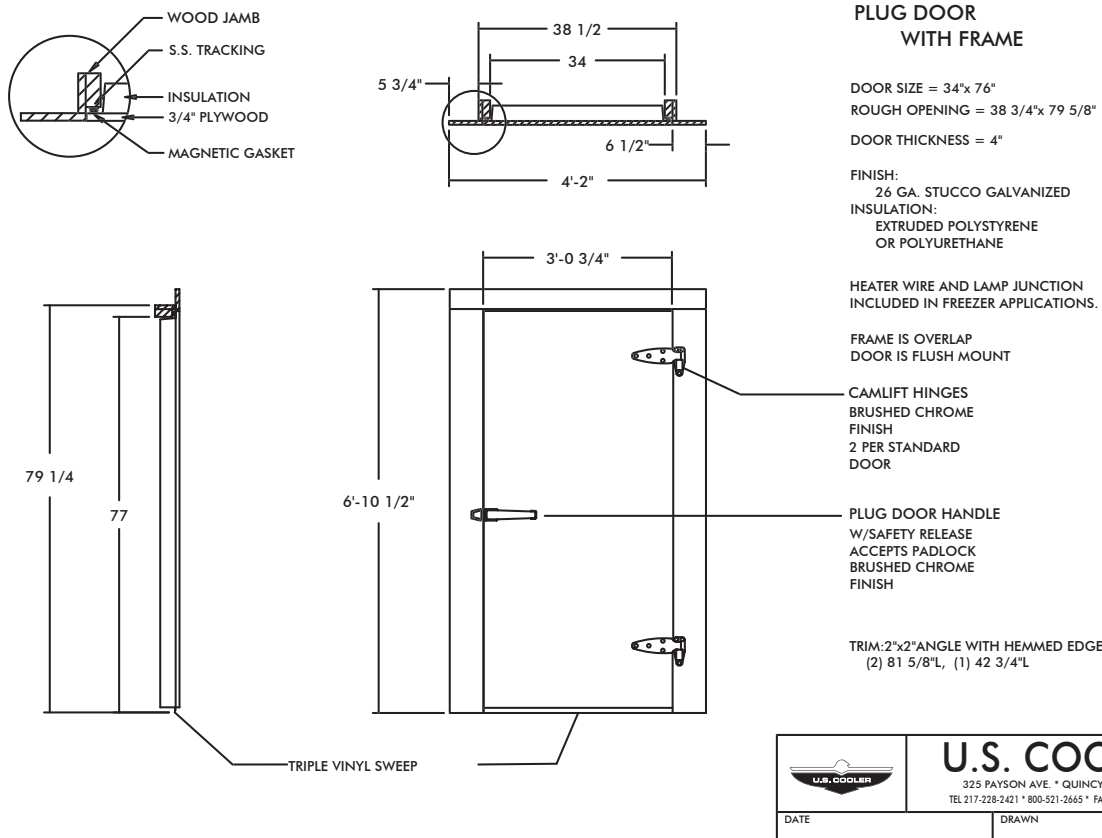
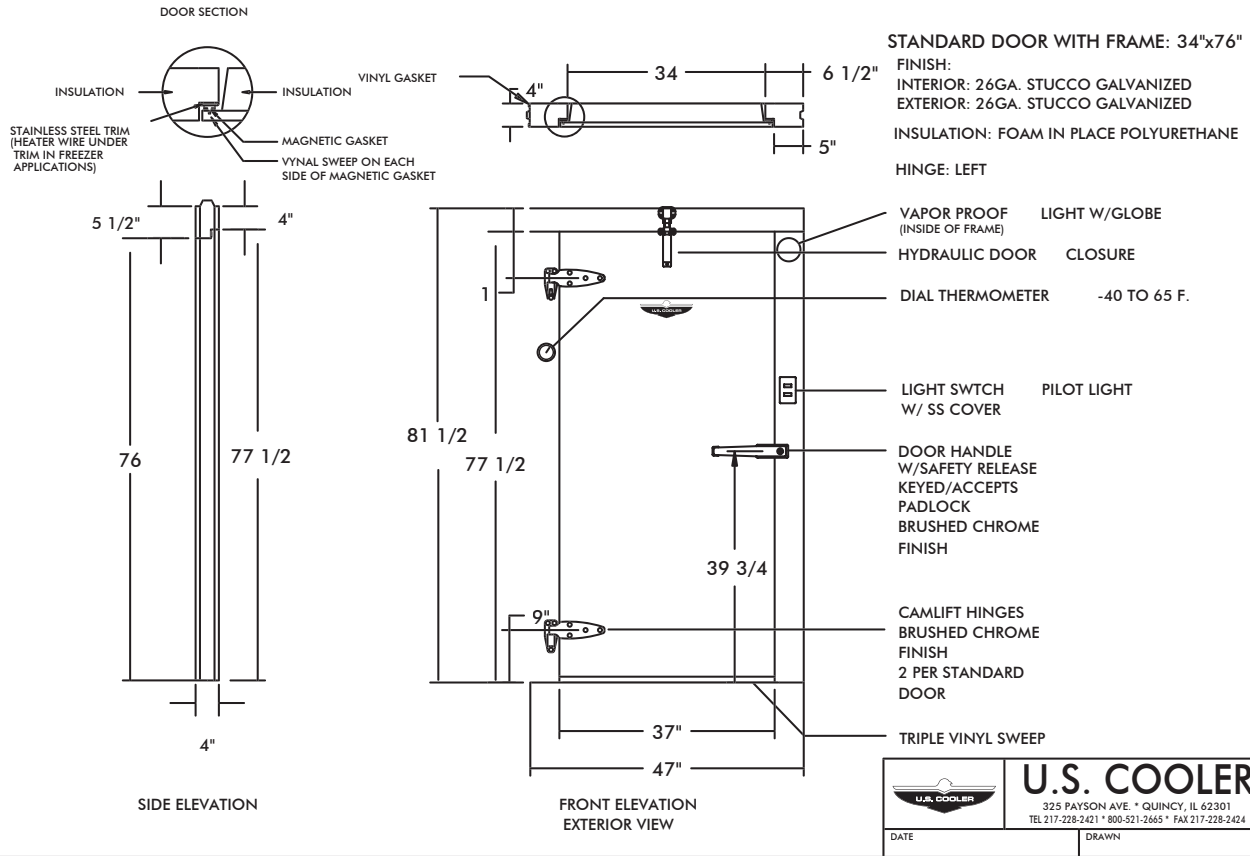

Ceiling and Footing Drawings

CEILING SUPPORT DETAIL

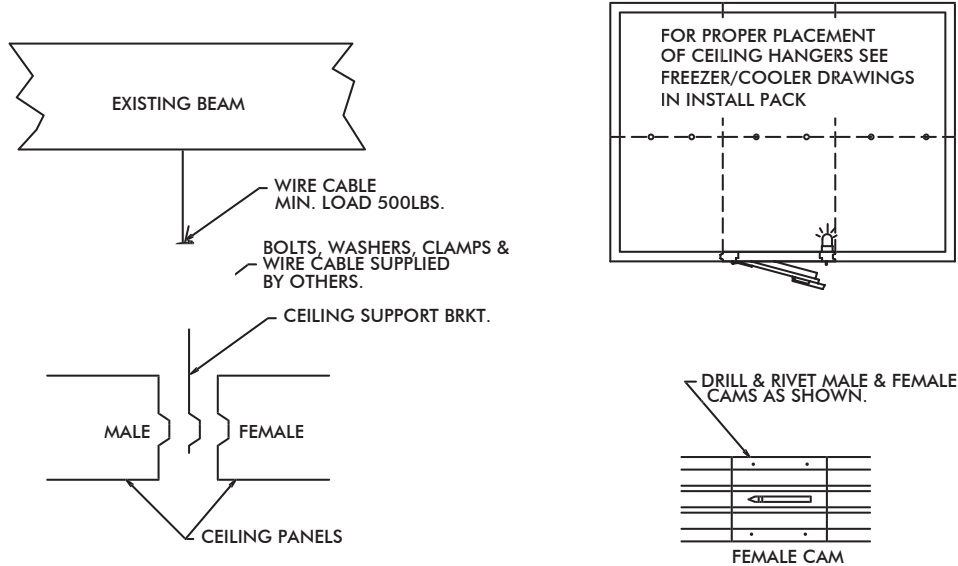

PLACE BRACKET BETWEEN MALE & FEMALE CAMS, LINING THE SLOT OF THE BRACKET UP WITH THE FEMALE SLOT AND THE MALE LOCK.

		U.S. COOLER <small>325 PAYSON AVE. * QUINCY, IL 62301 TEL 217-228-2421 * 800-521-2665 * FAX 217-228-2424</small>
DATE	DRAWN	

FOOTING DETAIL (FLOORLESS APPLICATION)

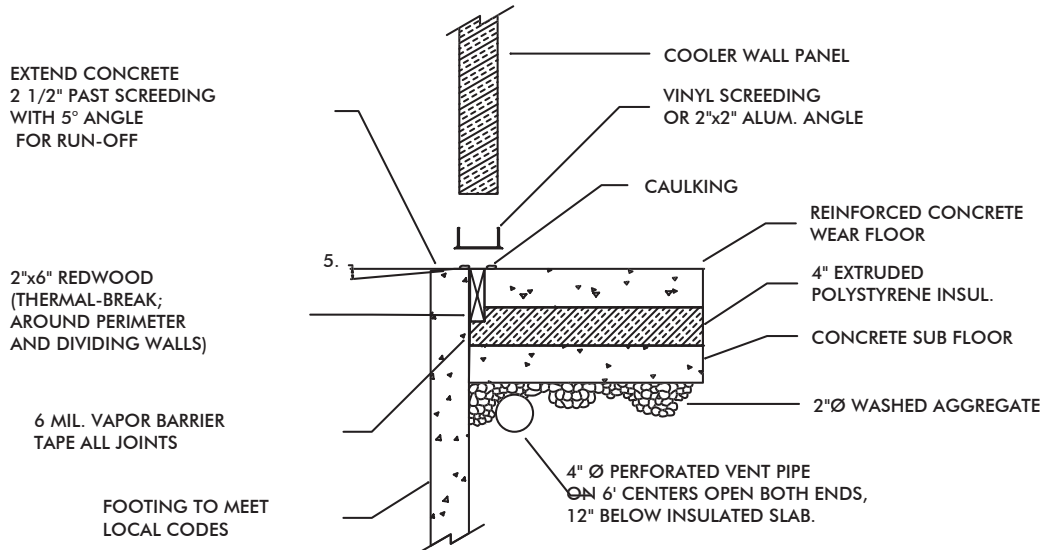

Design used for Conceptual purposes Consult local Engineer for requirements.
Craig Industries is not responsible for foundation design. This is an example.

		U.S. COOLER <small>325 PAYSON AVE. * QUINCY, IL 62301 TEL 217-228-2421 * 800-521-2665 * FAX 217-228-2424</small>
DATE	DRAWN	

Refrigeration Drawings

GENERAL ASSEMBLY FOR TOP MOUNT SELF-CONTAINED COOLER

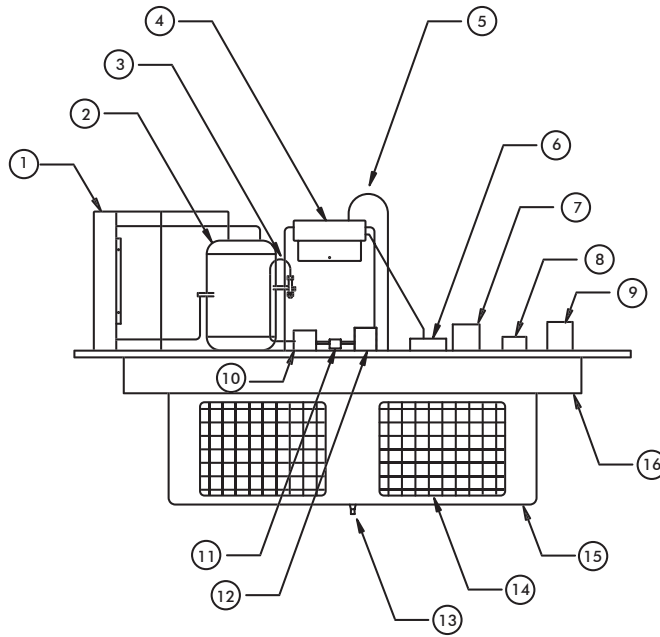

PARTS LIST	
#	PART
1	CONDENSER
2	RECEIVER
3	LIQUID LINE
4	COMPRESSOR
5	SUCTION LINE
6	POWER INLET
7	PRESSURE CONTROL
8	TIMER - FRZ. ONLY
9	TEMPERATURE CONTROL
10	DRIER
11	SIGHT GLASS
12	SOLENOID VALVE-FRZ. ONLY
13	DRAIN OUTLET
14	FAN
15	EVAPORATOR
16	PLUG

NOTE: PARTS AND LOCATIONS MAY VARY
DEPENDING ON UNIT



U.S. COOLER

325 PAYSON AVE. * QUINCY, IL 62301
TEL 217-228-2421 * 800-521-2665 * FAX 217-228-2424

DATE

DRAWN

INSTALL INSTRUCTIONS FOR EVAPORATOR DRAIN LINE

(INSTRUCTIONS APPLY TO REMOTE AND SELF CONTAIN UNITS)

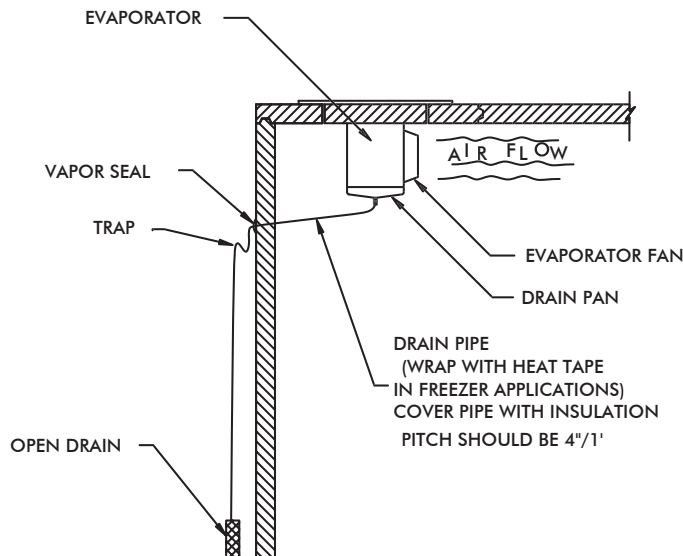

NOTE: DRAIN PIPE SIZES VARY
SEE FACTORY SPECIFICATIONS



U.S. COOLER

325 PAYSON AVE. * QUINCY, IL 62301
TEL 217-228-2421 * 800-521-2665 * FAX 217-228-2424

DATE

DRAWN

