



P-660 PIZZA MIXER

HOBART

STANDARD FEATURES

- 2½ H.P. Hobart Designed Fixed Speed Motor
- Gear-Driven Transmission
- 15 Minute Timer
- Two Fixed Speeds
- Open Base
- Large, Easy-To-Reach Controls
- #12 Taper Attachment Hub
- Stainless Steel Bowl Guard
- Manual Bowl Lift
- 60-Quart Stainless Steel Bowl, "ED" Dough Hook

MODELS

- P-660 – 60-Quart Pizza Mixer

Specifications, Details and Dimensions on Inside and Back.



ACCESSORIES

- Stainless Steel Bowl
- "B" Flat Beater
- Stainless Steel "B" Beater
- "C" Wing Whip
- "D" Wire Whip
- "E" Dough Hook
- "ED" Dough Hook
- "P" Pastry Knife
- "I" Heavy Duty Wire Whip
- Bowl Extension Ring
- Bowl Splash Cover
- Bowl Scraper
- Bowl Adapter
- Bowl Truck and Bowl Truck Adapter
- 40 and 30 Quart Accessories
- 6" Attachment Tray Support
- 9" Attachment Tray Support
- Ingredient Chute
- 9" Vegetable Slicer
- Meat Chopper Attachment

P-660 PIZZA MIXER

P-660 PIZZA MIXER



SOLUTIONS/BENEFITS

2½ H.P. Hobart Designed Motor

Durability

- Heavy-duty to meet the most demanding pizza operations

15-Minute Electric Timer

Convenience, Ease of Use, Consistency

- Supports recipe mixing times
- Simplifies operation
- Provides accurate results and eliminates overmixing

Two Fixed Speeds

Flexibility, Reliability, Consistency

- For incorporating, blending, mixing ingredients
- Supports consistent results and thorough mixing
- Supports optimum speeds for heavy dough mixing

Bowl Guard

Protection

- Safety interlock prevents operation when front portion of guard is out of position

Gear-Driven Transmission

Durability, Reliability

- Ensures consistent performance and minimum downtime with positive drive under heavy loads

Hobart Attachments

Durability, Flexibility

- Hobart manufactured accessories are designed for long-term usage under heavy-duty conditions
- Large array of attachments provide multiple uses for recipe and product processing

P-660 MIXER CAPACITY CHART

Recommended Maximum Capacities - dough capacities based on 70°F. water and 12% flour moisture.

PRODUCT	AGITATORS SUITABLE FOR OPERATION	P-660
CAPACITY OF BOWL (QTS. LIQUID)		60
Egg Whites	D	—
Mashed Potatoes	B & C	—
Mayonnaise (Qts. of Oil)	B or C or D	—
Meringue (Qts. of Water)	D	—
Waffle or Hot Cake Batter	B	—
Whipped Cream	D or C	—
Cake, Angel Food (8-10 oz. cake)	C or I	—
Cake, Box or Slab	B or C	75 lbs.
Cake, Cup	B or C	70 lbs.
Cake, Layer	B or C	70 lbs.
Cake, Pound	B	75 lbs.
Cake, Short (Sponge)	C or I	—
Cake, Sponge	C or I	—
Cookies, Sugar	B	50 lbs.
Dough, Bread or Roll (Lt.-Med.) 60% AR	§ ED	90 lbs.*
Dough, Heavy Bread 55% AR	§ ED	85 lbs.*
Dough Pie	B & P	60 lbs.
Dough, Thin Pizza 40% AR (max. mix time 5 min.)	§ ED	60 [□] /40 lbs.*
Dough, Med. Pizza 50% AR	§ ED	90 [□] /70 lbs.*
Dough, Thick Pizza 60% AR	§ ED	90 lbs.*
Dough, Raised Donut 65% AR	ED	75 lbs.*
Dough, Whole Wheat 70% AR	ED	90 lbs.*
Eggs & Sugar for Sponge Cake	B & C or I	—
Icing, Fondant	B	—
Icing, Marshmallow	C or I	—
Shortening & Sugar, Creamed	B	50 lbs.
Pasta, Basic Egg Noodle (max. mix time 5 min.)	ED	40 lbs. [□]

NOTE: % AR (% Absorption Ratio) - Water weight divided by flour weight. Capacity depends on moisture content of dough. Above capacities based on 12% flour moisture at 70°F water temperature.

□ 1st Speed

* 2nd Speed

§ If high gluten flour is used, reduce above dough batch size by 10%.

USE OF ICE REQUIRES A 10% REDUCTION IN BATCH SIZE.

1 gallon of water weighs 8.33 lbs.

NOTE: Attachment hub should not be used while mixing.

SPECIFICATIONS

MOTOR:

2½ H.P., Hobart designed, high torque ball bearing, ventilated within mixer enclosure. Single-phase is capacitor-start, induction-run type. Three-phase is polyphase squirrel cage, induction-run type.

Single Phase	208V 240V	20.0 Amps 17.0 Amps
Three Phase	208-240V	8.6 Amps

ELECTRICAL:

Furnished in 208-240/60/3, 208/60/1 and 240/60/1 – U L Listed. Also available in 400/50/3 – not submitted for U L Listing.

CONTROLS:

Magnetic contactor with automatic resetting bimetallic thermal overload protection internally mounted. “Start-Stop” push buttons protected by rubber caps. A 15-minute electric timer is standard.

TRANSMISSION:

Gear-driven. Gears are constant mesh heat-treated alloy steel. A hardened steel worm and alloy bronze worm gear transmit power from motor to transmission. All shafts are mounted in ball or roller bearings. Circulating oil lubricant furnished to all gears. Visual type transmission oil level gauge.

SPEEDS:

Two positive speeds -

	Agitator (RPM)	Attachment (RPM)
1. First	56	175
2. Second	96	305

BOWL GUARD:

Heavy-duty stainless steel wire front and solid stainless steel rear portion. Front portion of guard rotates easily to add ingredients and install or remove agitator. It detaches in seconds for cleaning in dishwasher or sink. Rear portion of guard can be quickly cleaned in position. Guard must be in closed position before mixer will operate. The bowl support lock prevents the bowl from being lowered while mixer is running. Bowl support interlock provides further protection.

BOWL LIFT:

Hand operated, self-locking in any position.

FINISH:

Standard Metallic Gray finish, Polyurethane Enamel.

STANDARD EQUIPMENT:

Consists of the mixer unit with one (1) 60-quart stainless steel bowl, one (1) “ED” dough hook and stainless steel bowl guard.

ATTACHMENT HUB:

Comes with front-mounted Hobart standard #12 taper attachment hub for use with #12 size attachments.

NOTE: Use of attachment hub during mixing operation may result in a negative impact on performance and longevity of mixer.

ATTACHMENTS AND ACCESSORIES:

The following are available at extra cost:

- Stainless Steel Bowl
- “B” Flat Beater
- Stainless Steel “B” Beater
- “C” Wing Whip
- “D” Wire Whip
- “E” Dough Hook
- “ED” Dough Hook
- “P” Pastry Knife
- “I” Heavy Duty Wire Whip
- Bowl Extension Ring
- Bowl Splash Cover
- Bowl Scraper
- Bowl Adapter
- Bowl Truck and Bowl Truck Adapter
- 40 and 30 Quart Accessories
- 6" Attachment Tray Support
- 9" Attachment Tray Support
- Ingredient Chute
- 9" Vegetable Slicer
- Meat Chopper Attachment



Hobart Bowl Scraper



Hobart Ingredient Chute

LISTED BY: Underwriters Laboratories, Inc. and the National Sanitation Foundation. Certified by the Baking Industry Sanitation Standard Committee.

P-660 PIZZA MIXER



SPECIFICATIONS

ELECTRICAL SPECIFICATIONS: Furnished in 208-240/60/3, 208/60/1 and 240/60/1 – U L Listed. Also available in 400/50/3 – not submitted for U L Listing.

WEIGHT: 853 lbs. net; 880 lbs. domestic shipping.

WARRANTY: Unit has full one-year warranty on parts, labor and mileage against manufacturer's defects. Service contracts are available.

DETAILS AND DIMENSIONS

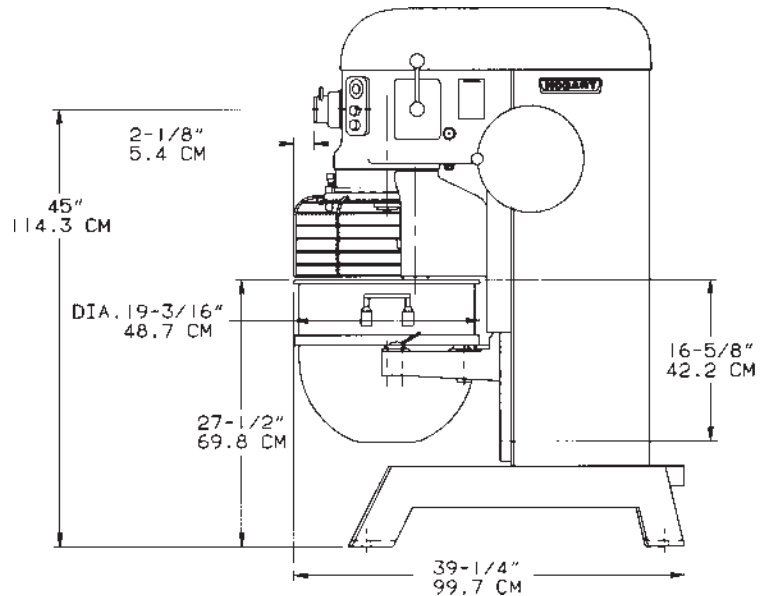
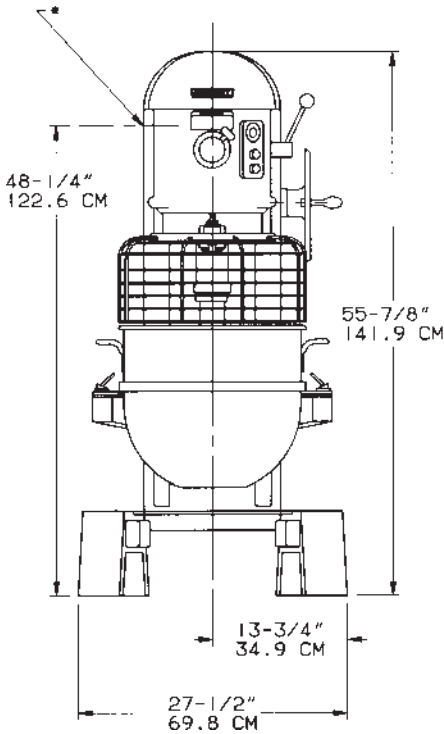
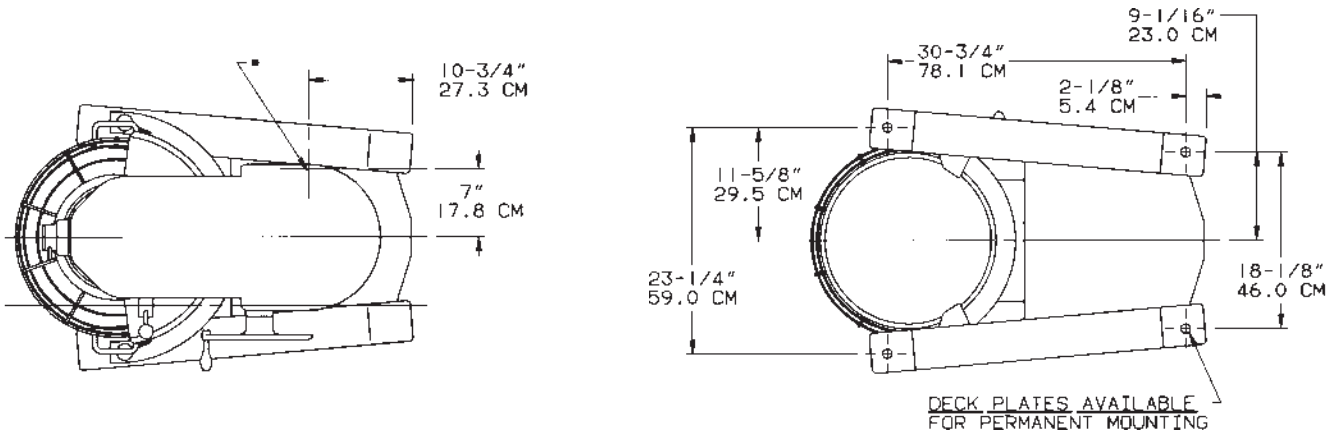

* DENOTES 1-1/16" HOLE FOR ELECTRICAL CONNECTION

NOTE:
BOLTING TO FLOOR
UNNECESSARY
EXCEPT ON SHIPBOARD

WARNING
ELECTRICAL AND GROUNDING
CONNECTIONS MUST COMPLY WITH
THE APPLICABLE PORTIONS OF
THE NATIONAL ELECTRICAL CODE
AND/OR OTHER LOCAL ELECTRICAL
CODES.